

EXAMPLE

15. A REALISTIC IC FEEDBACK AMPLIFIER

Example 1: Noninverting Amplifier with nonflat H_∞

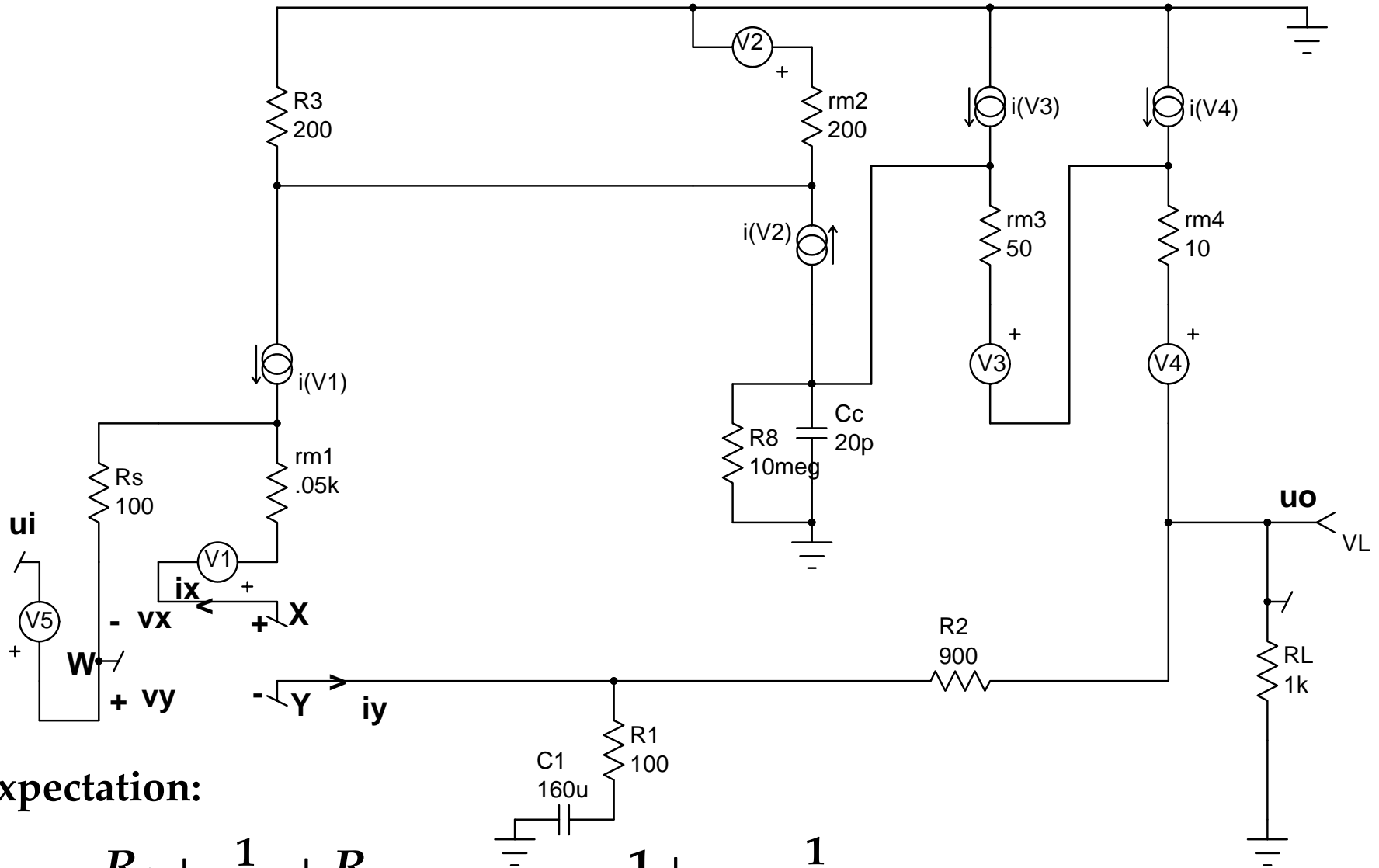

Expectation:

$$H_\infty = \frac{R_1 + \frac{1}{sC_1} + R_2}{R_1 + \frac{1}{sC_1}} = \frac{R_1 + R_2}{R_1} \frac{1 + \frac{1}{sC_1(R_1 + R_2)}}{1 + \frac{1}{sC_1 R_1}}$$

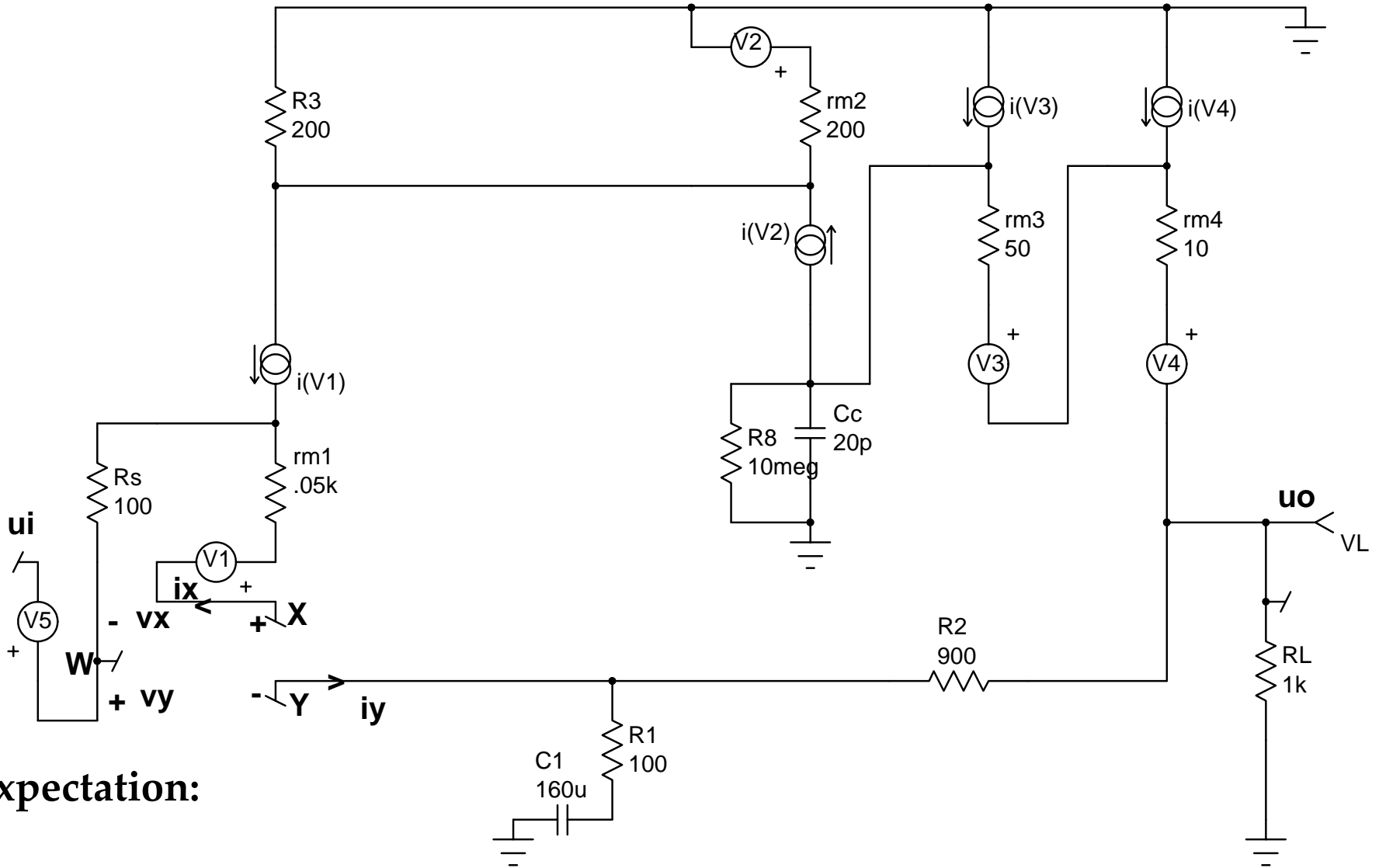

Expectation:

T should be flat at low frequencies, with a small shelf due to C_1 , plus a dominant pole due to C_c .

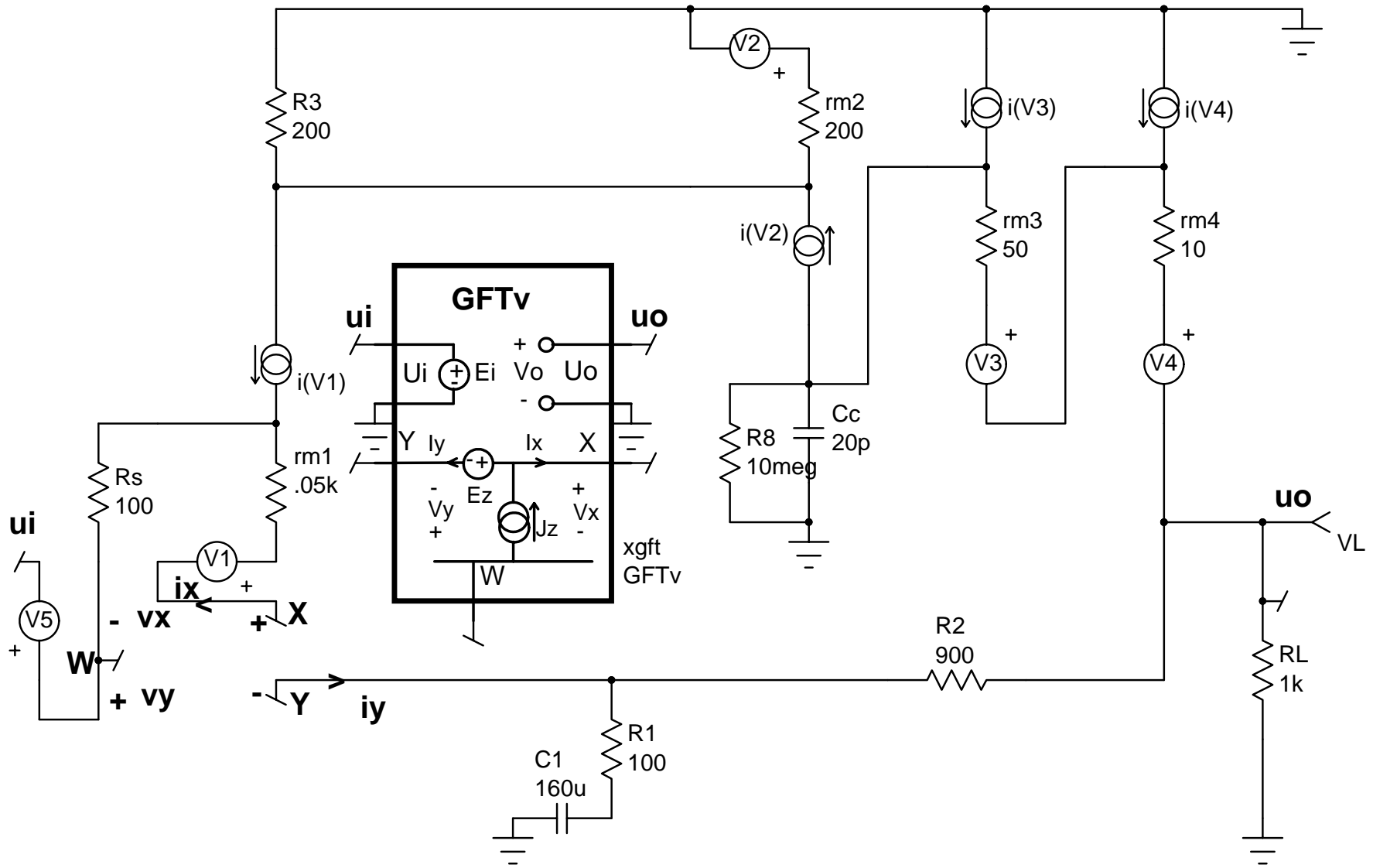

This Test Signal Injection Configuration meets the two requirements

The expectations are borne out:

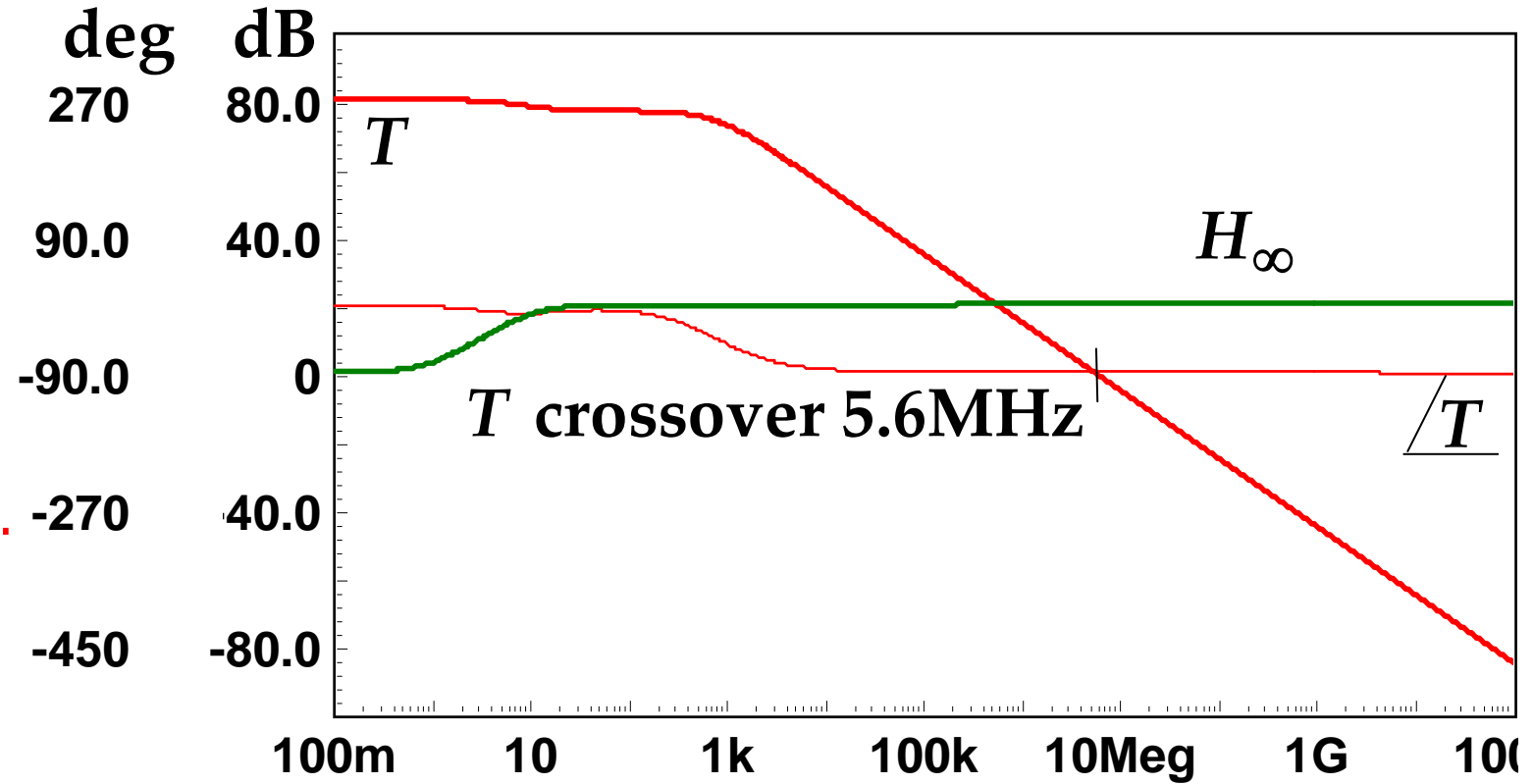

The discrepancy factor D should be flat at 0dB at low frequencies, with a dominant pole at the T crossover frequency, beyond which $T = D$:

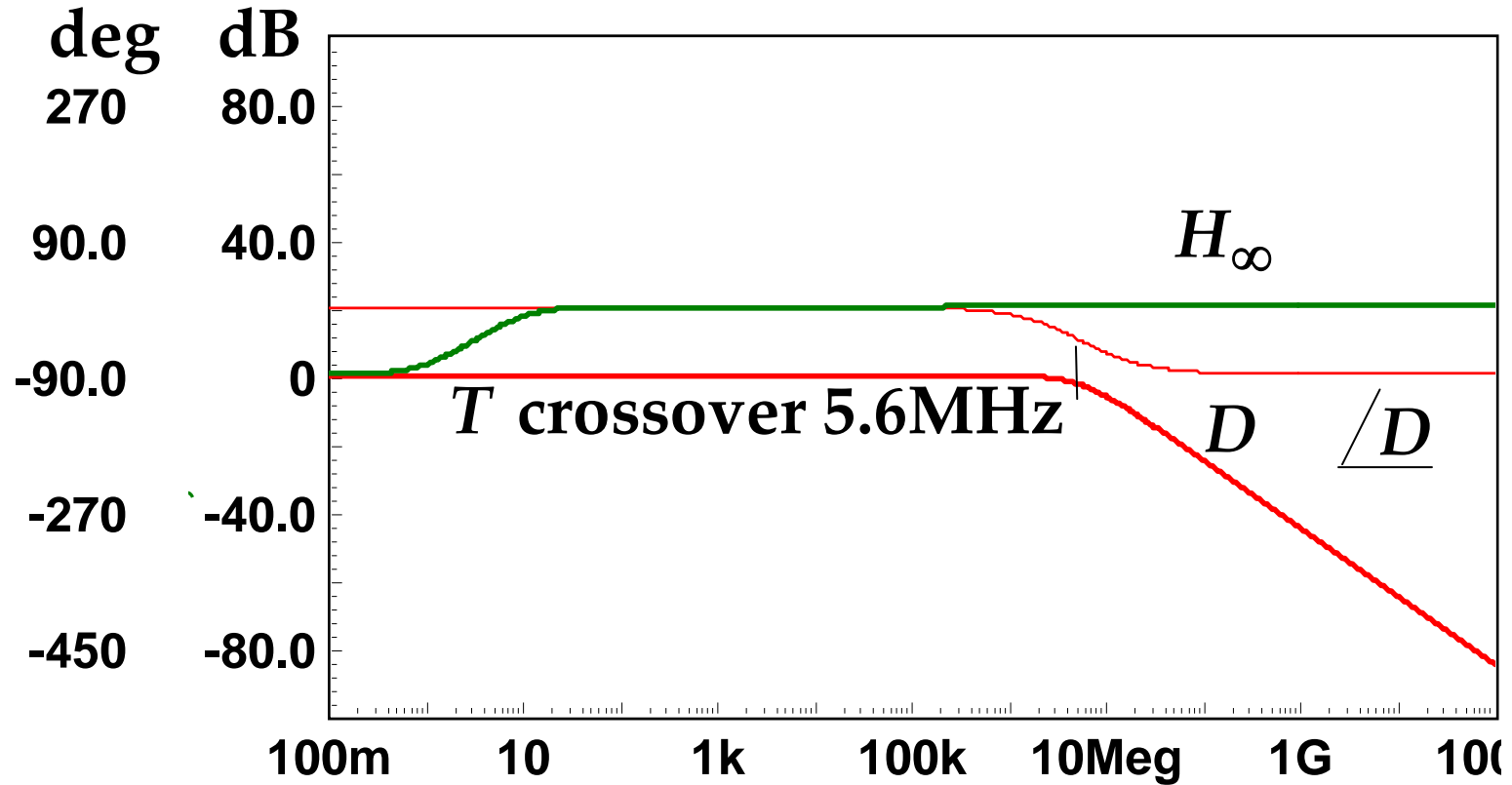

The null discrepancy factor D_n would be 0dB at all frequencies,

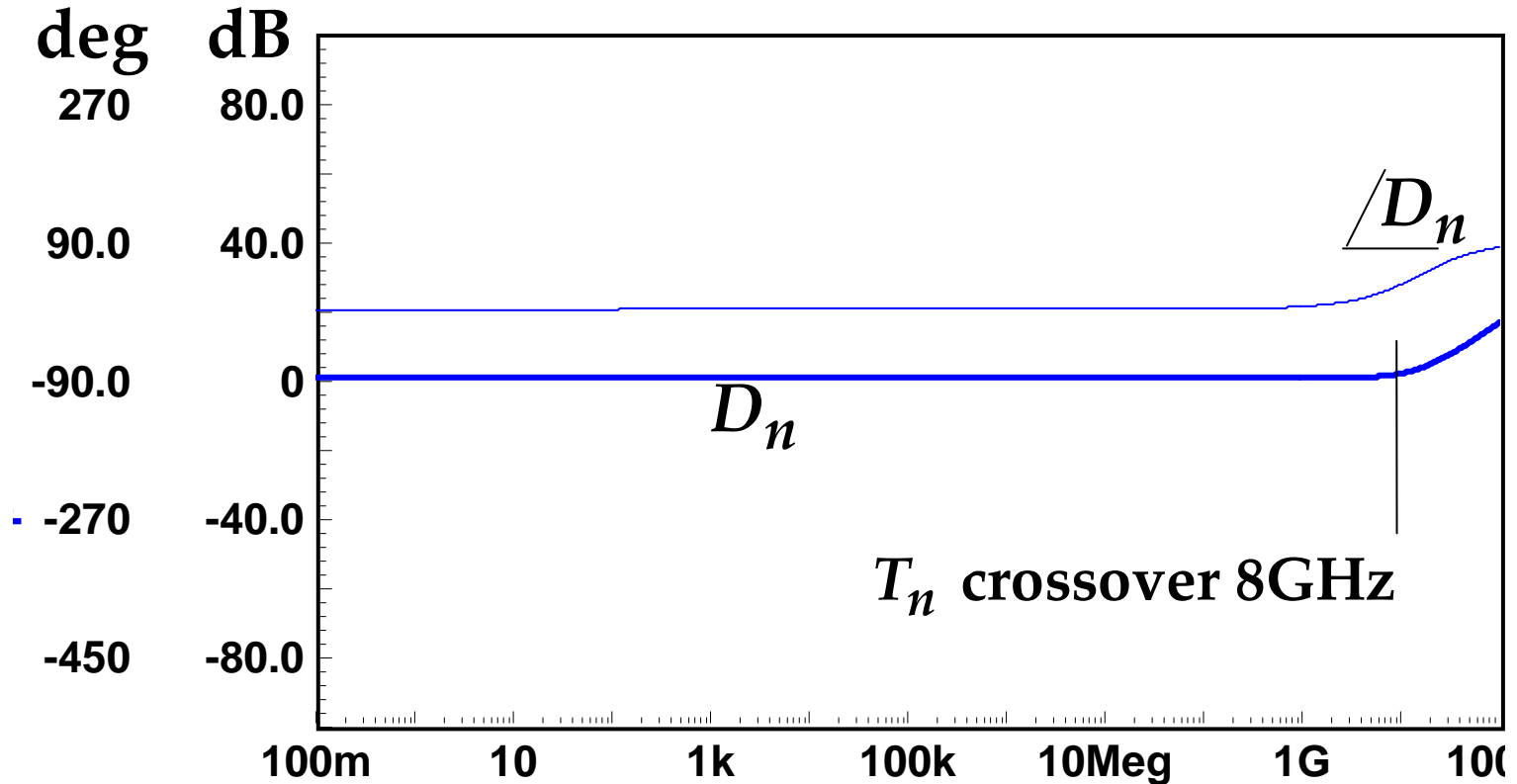

but the nonideality direct forward transmission through the feedback path causes D_n , above the T_n crossover frequency, to rise.

Assembled results:

The closed-loop gain H follows H_∞ up to T crossover, then falls with D . However, H levels off above T_n crossover:

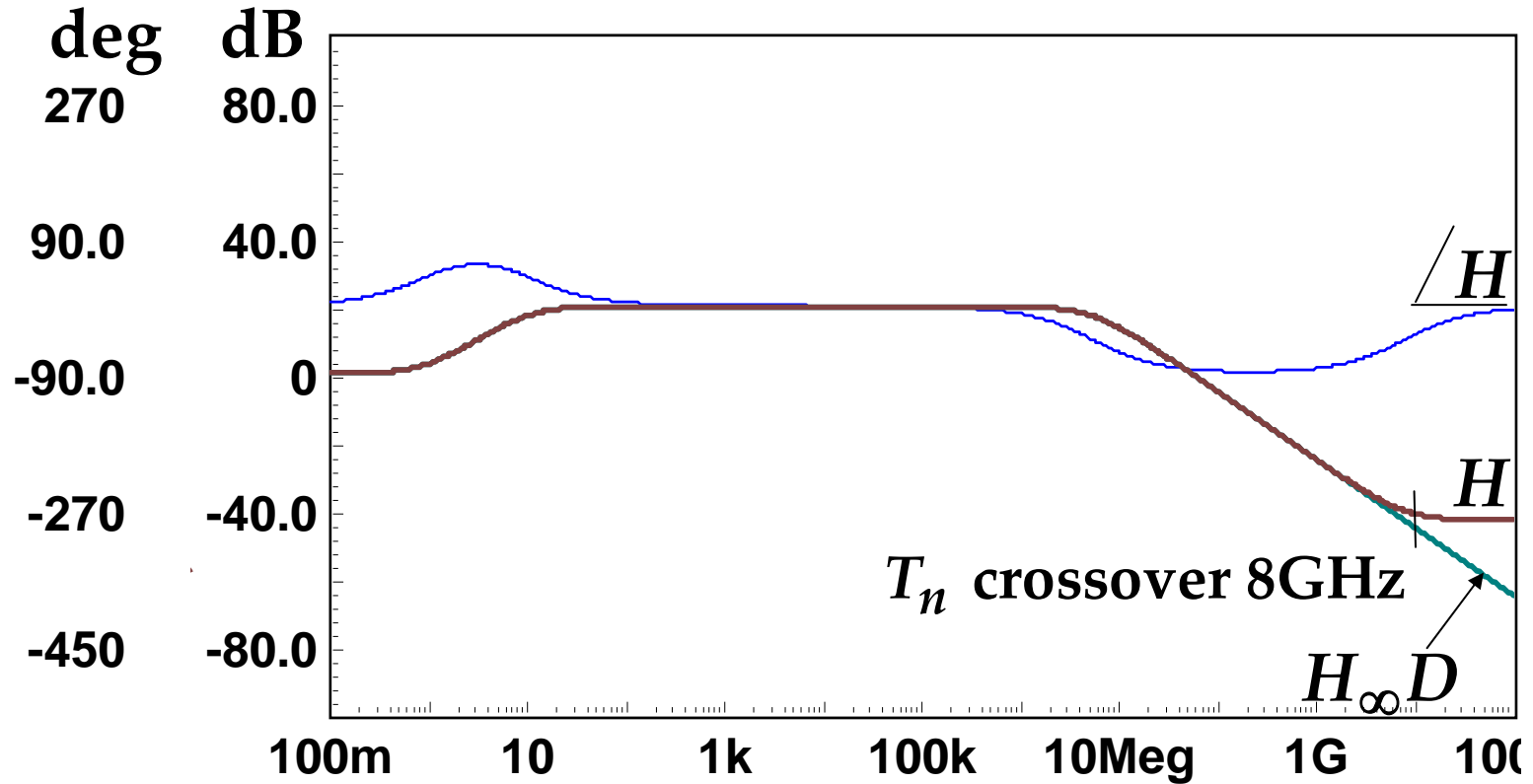

The nonideality is negligible.

Same basic circuit, but many device capacitances included:

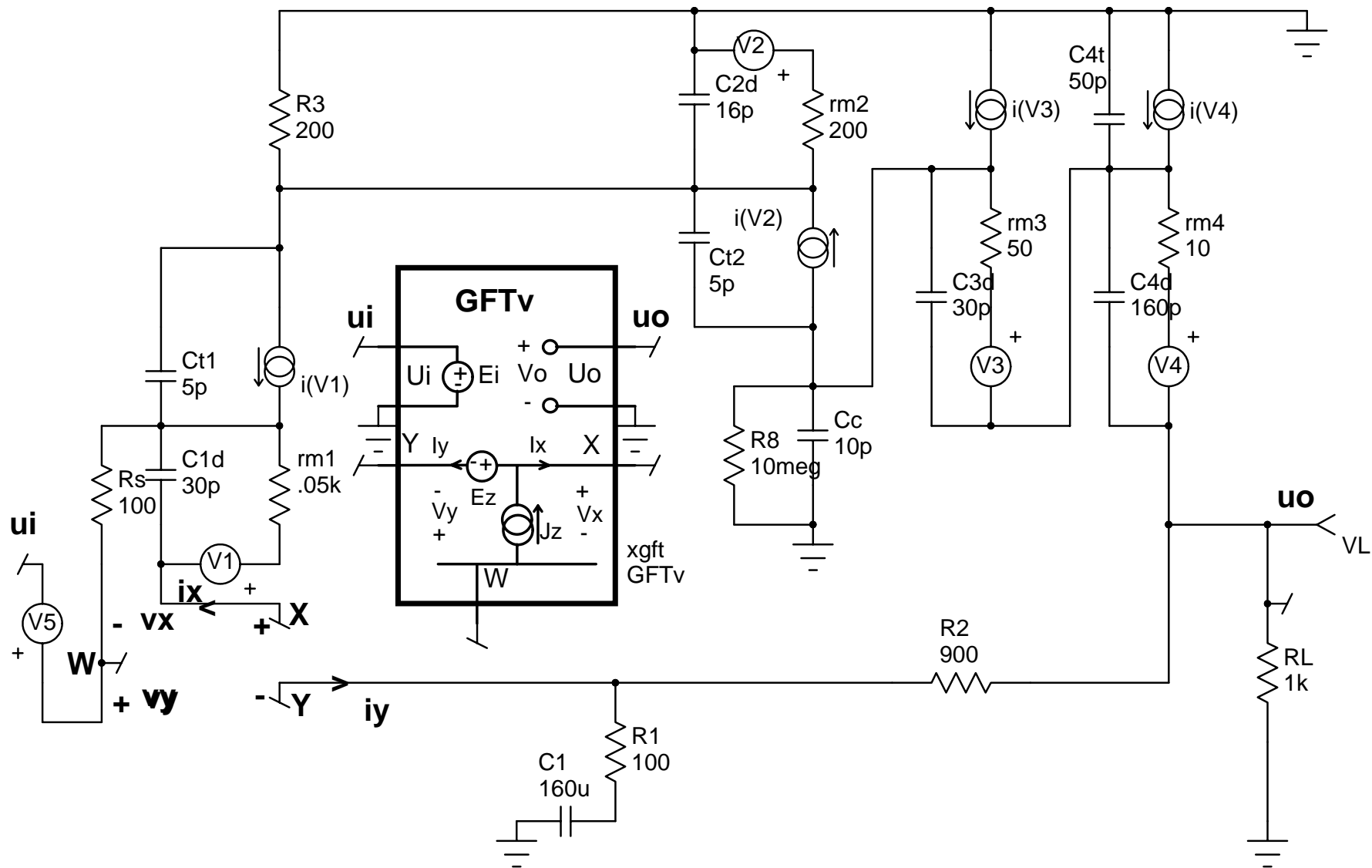

These cause additional nonidealities: reverse transmission in the forward path, and nonzero reverse loop gain.

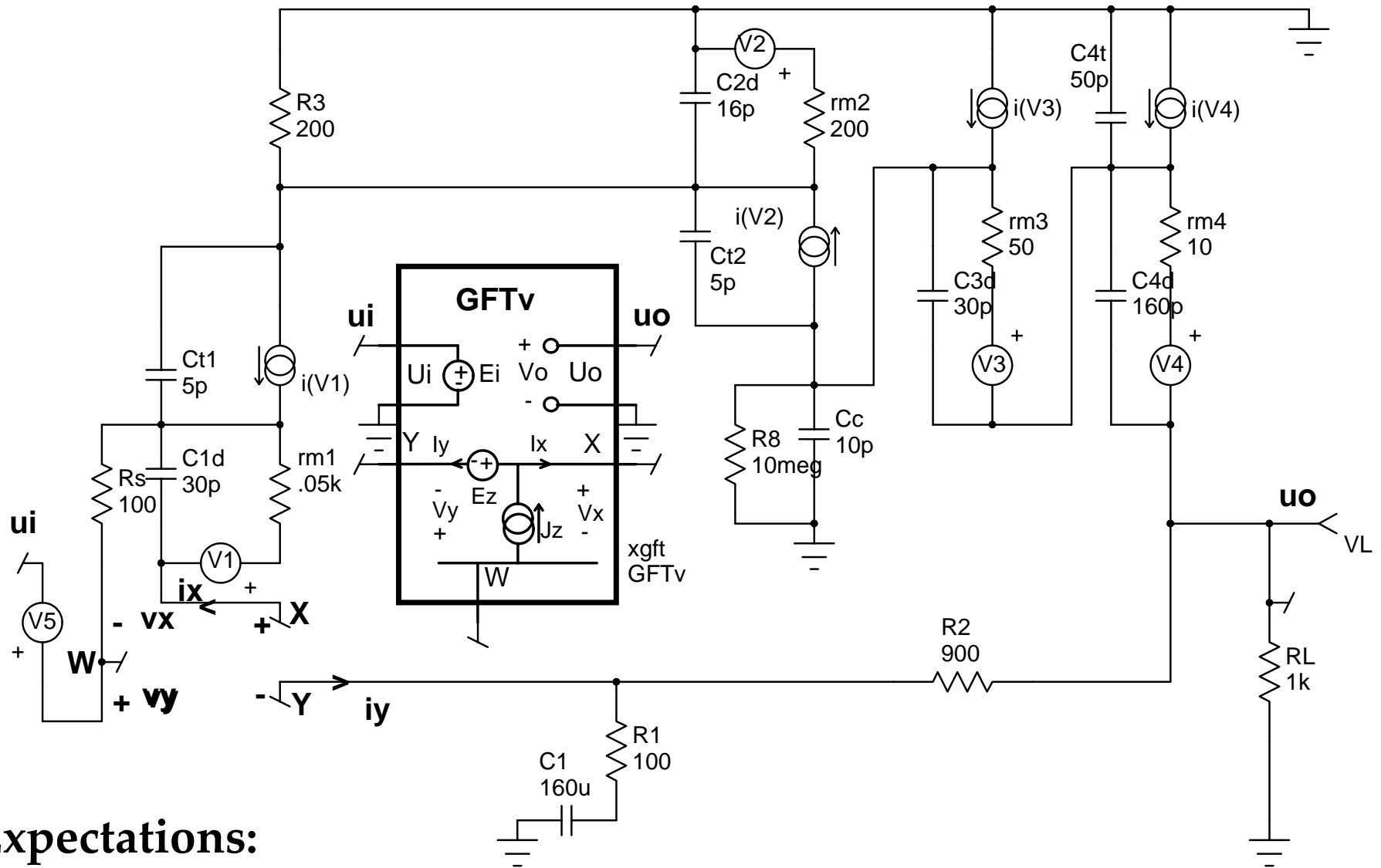

Expectations:

**T crossover is lowered ; high-frequency T is more complicated;
 phase margin is lowered**

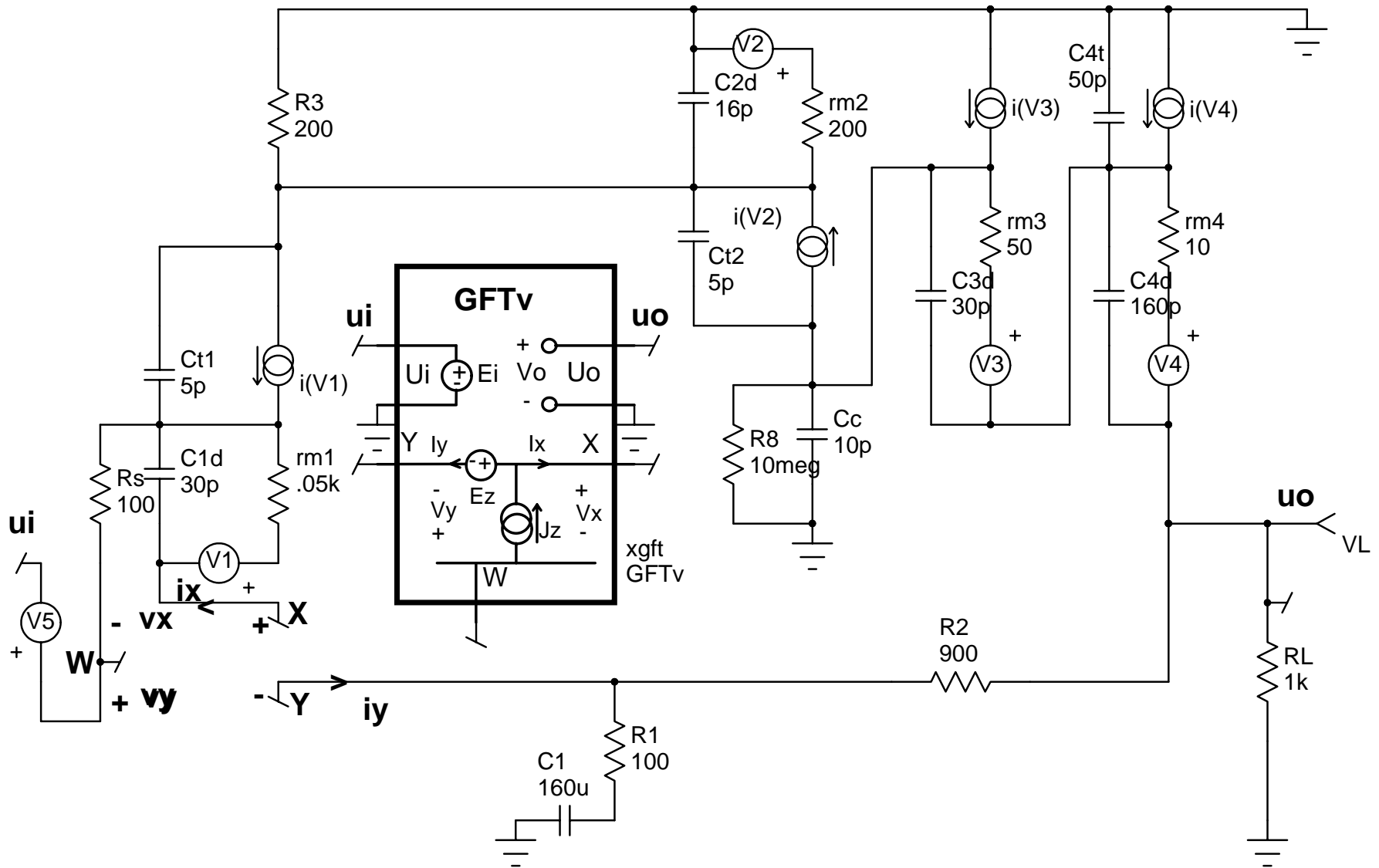

To retain about the same crossover frequency of 5.6MHz, C_c has been lowered from 20pF to 10pF.

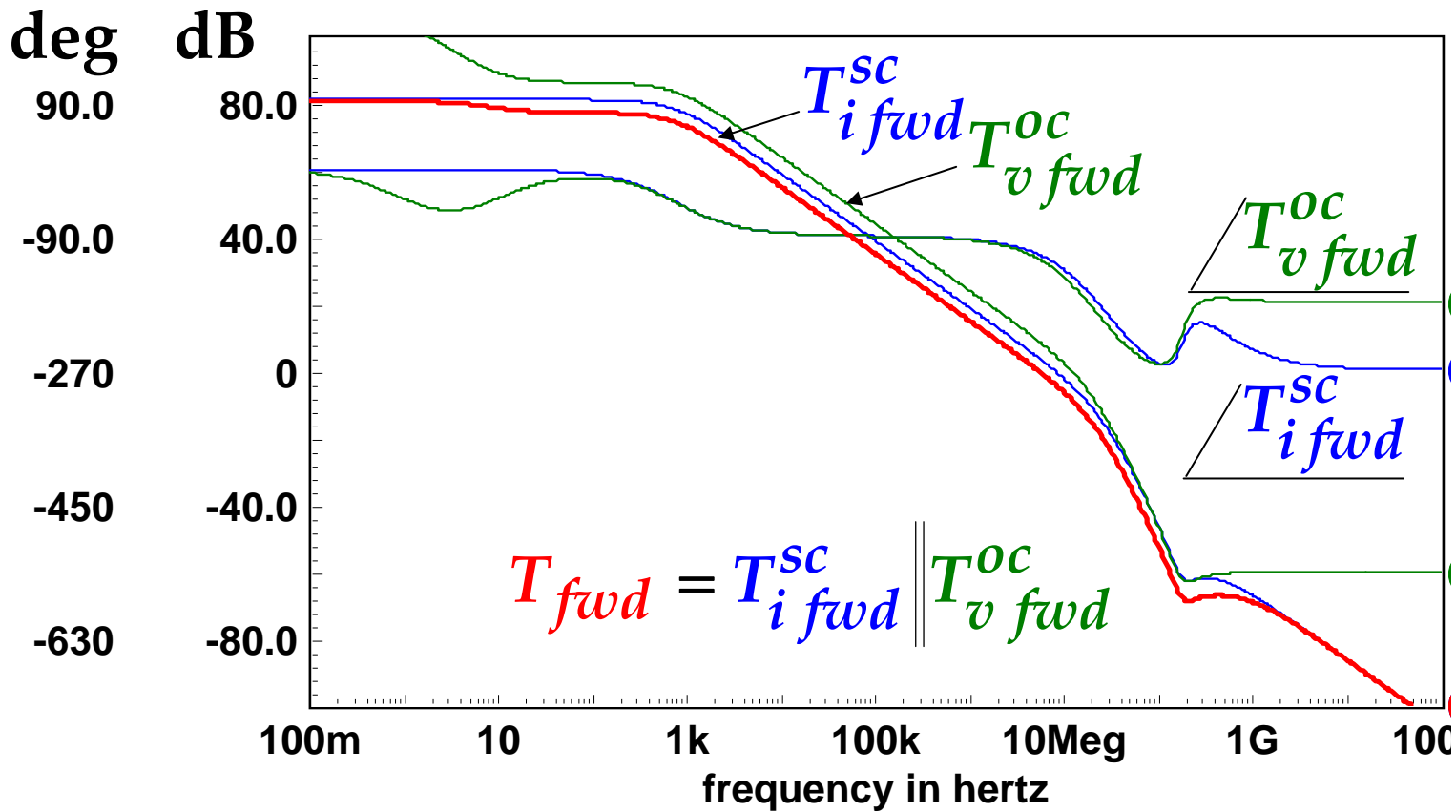

The expectations are borne out:

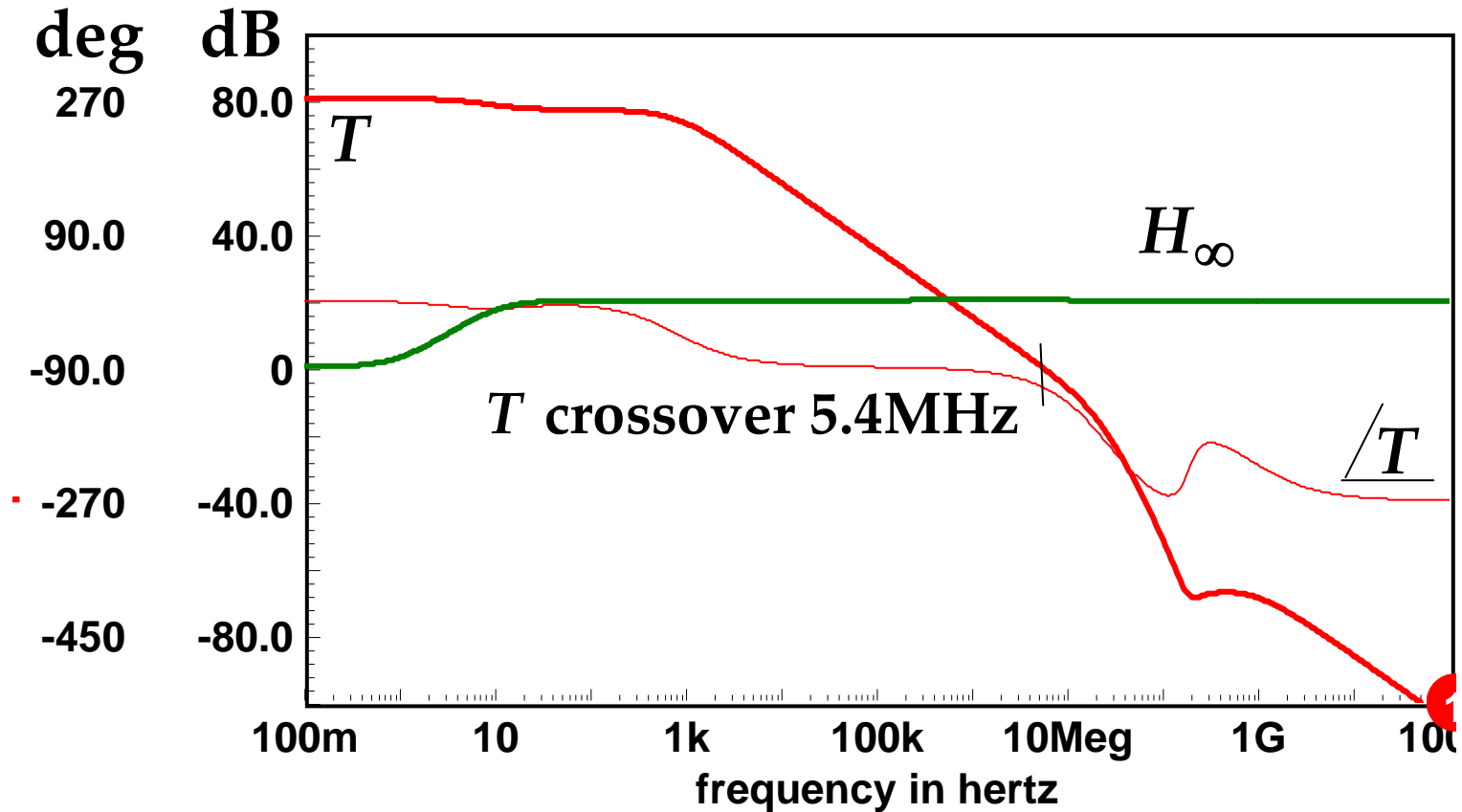

Beyond T crossover, $D = T$ and therefore is also more complicated:

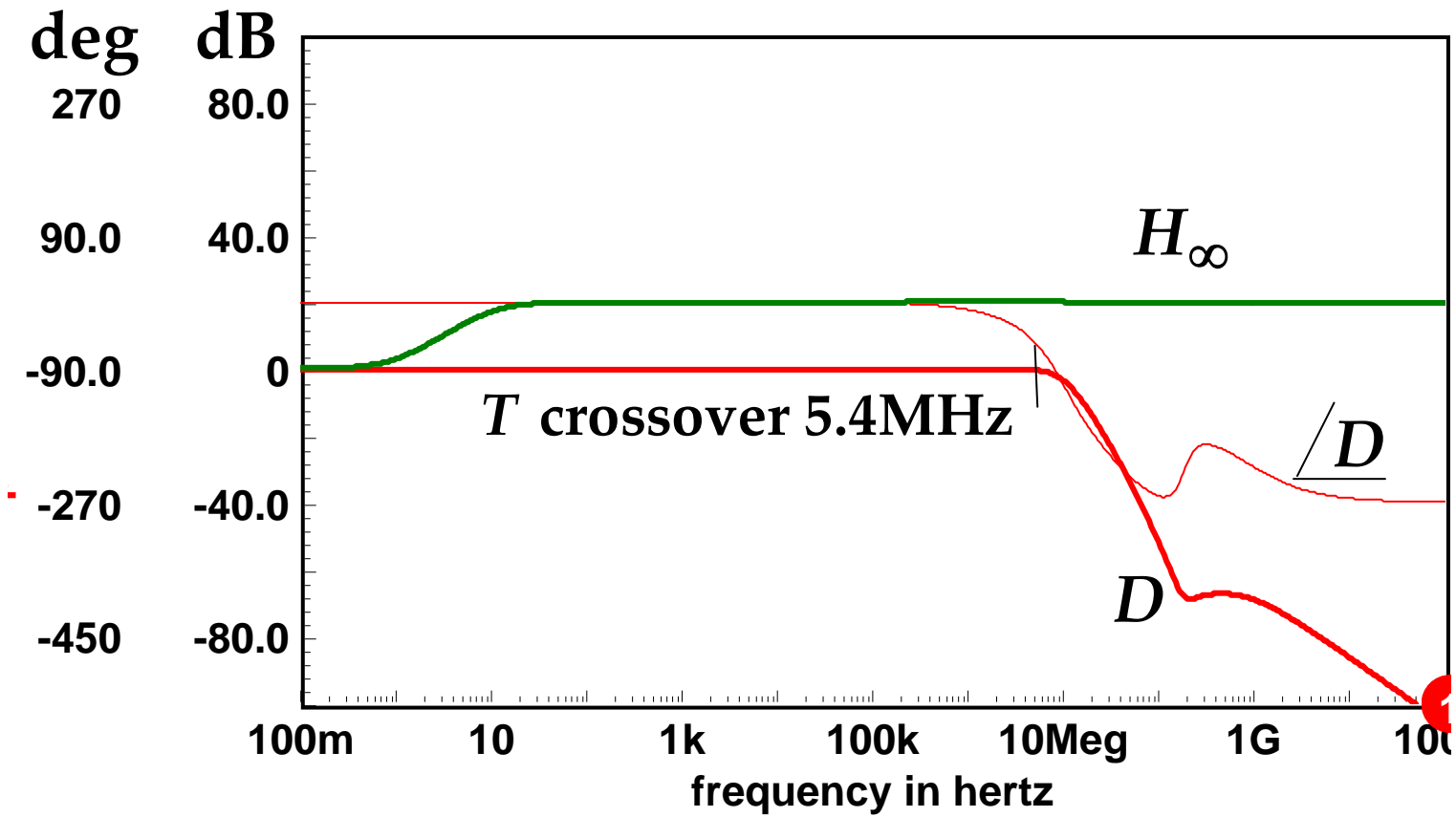

The T_n crossover is drastically lowered from 16GHz to 82MHz:

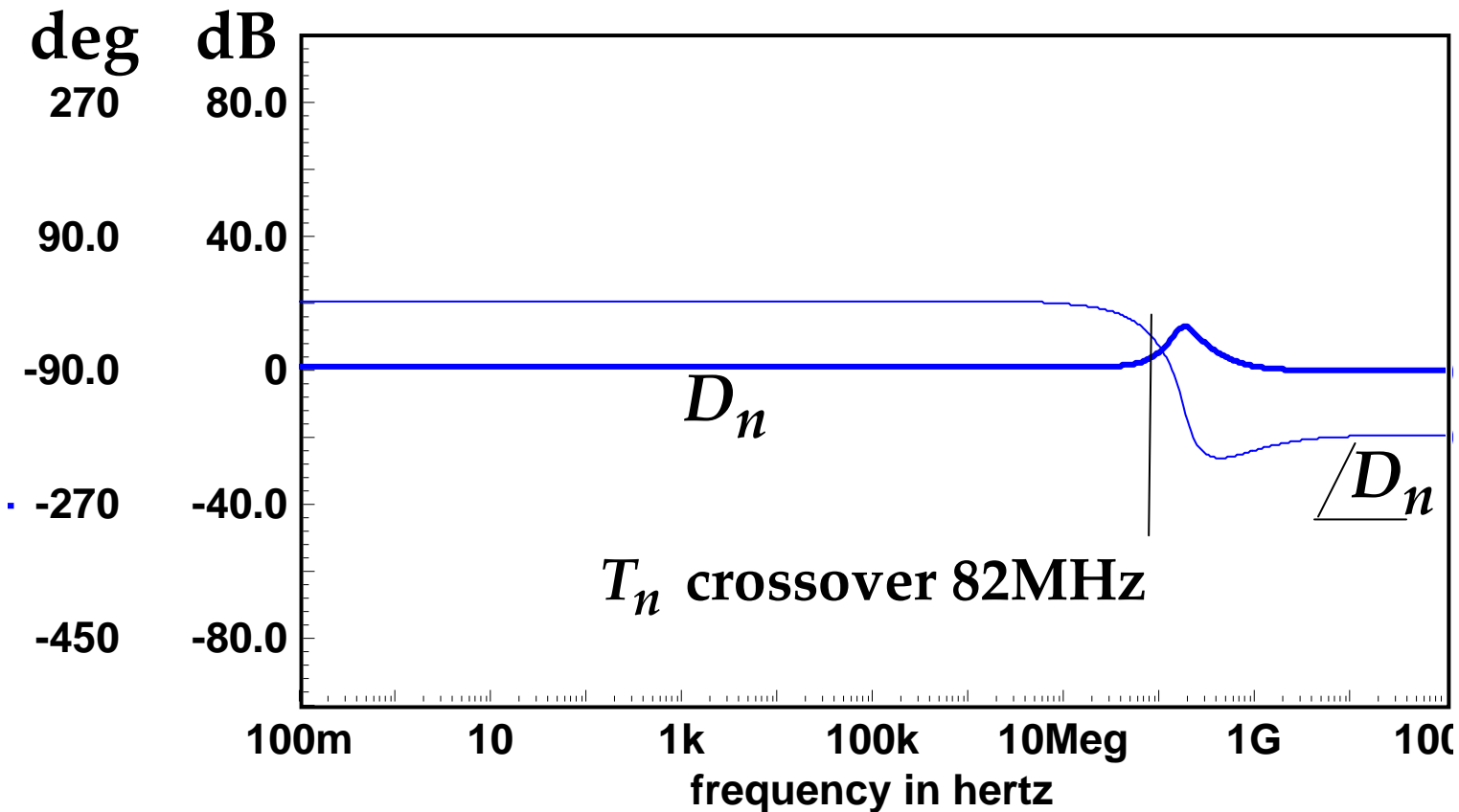

Even though D_n is approximately 0dB at both low and high frequencies, it undergoes a complete phase reversal

The major effect of the additional nonidealities is to cause \underline{H} to fall off much more rapidly,

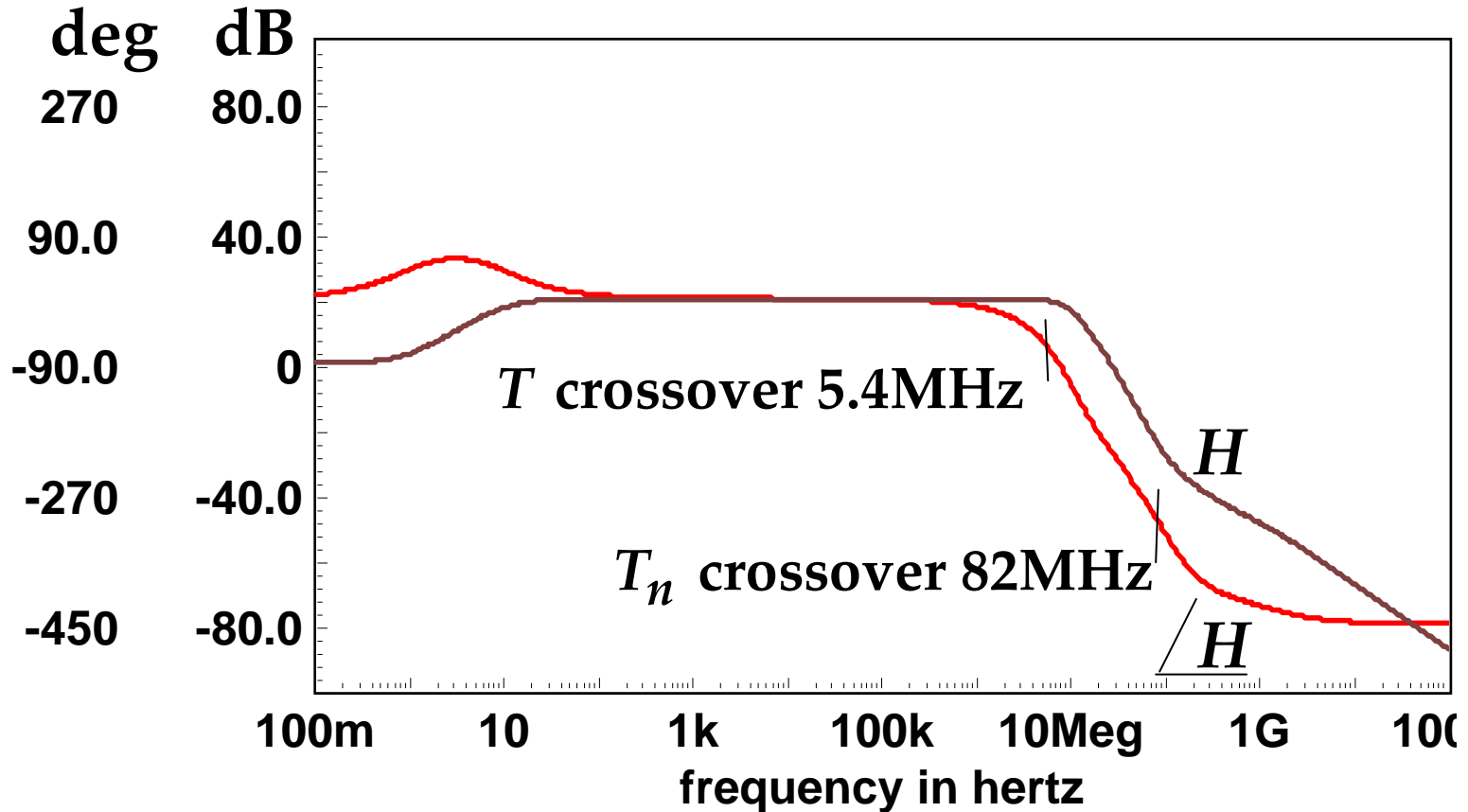

and it is now asymptotic to -450° instead of to 0° !

The transient response is therefore strongly degraded.

Step response:

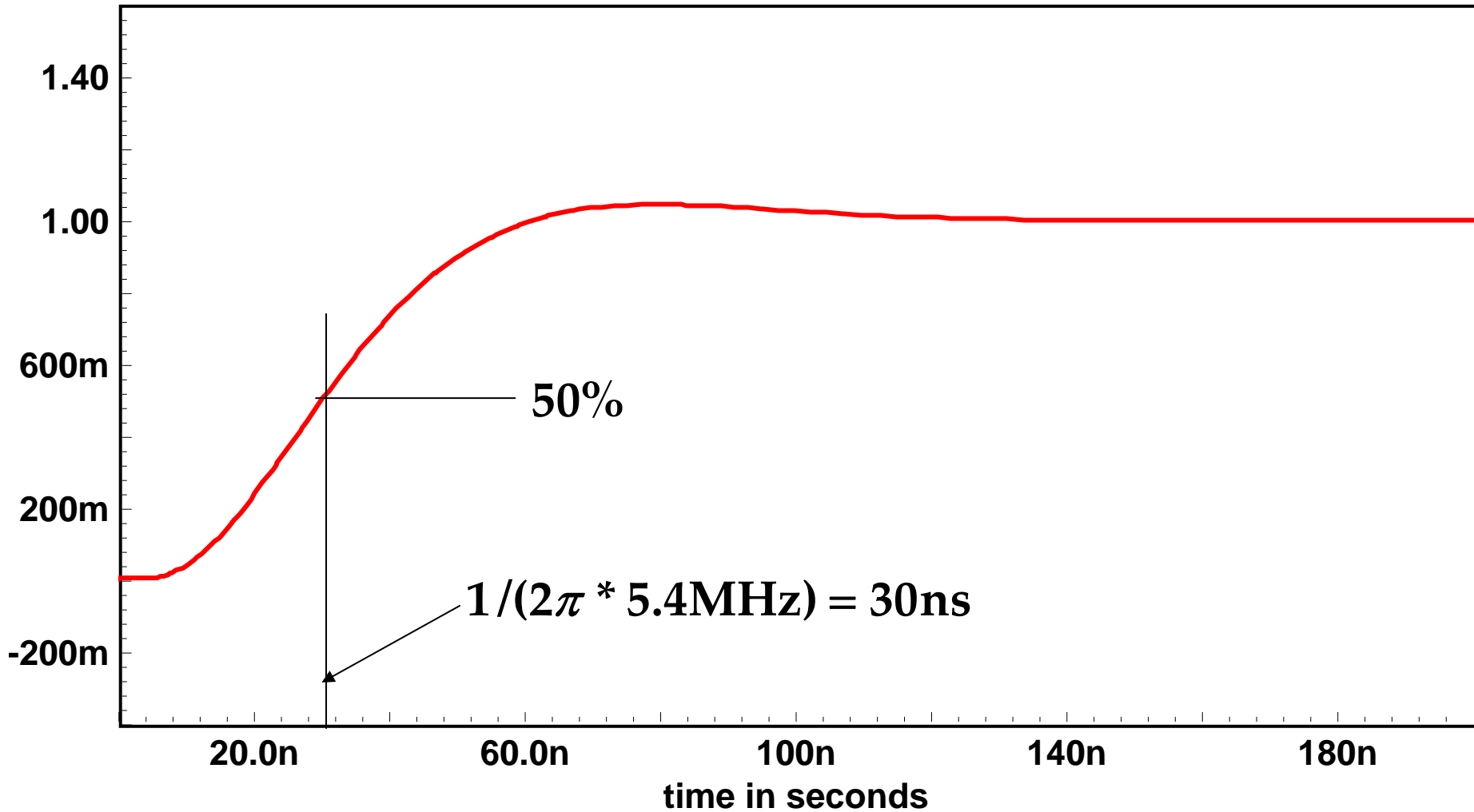

Add step response with C_c only:

